

McCULLOCH®

32cc / 35cc GASOLINE POWERED CHAIN SAWS

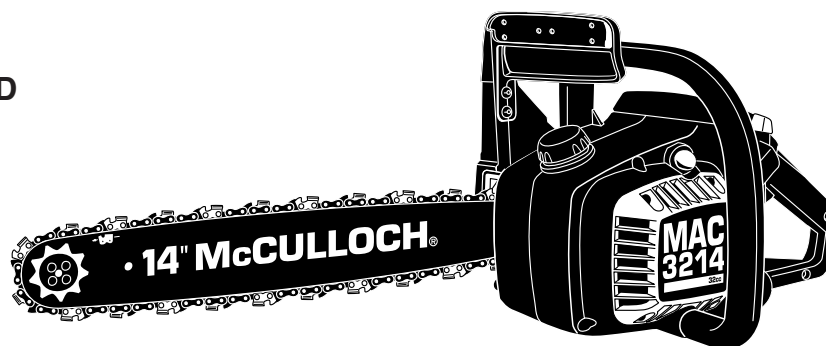

MODEL NAME	(+)SERIAL NUMBER PREFIX	MODEL NUMBER	BAR & CHAIN	ENGINE SIZE
MS1432	-	-	14"	32cc
MS1435	-	-	14"	35cc
MS1635NAV	-	-	16"	35cc
EAGER BEAVER 2010	11-	600032-11	10"	32cc
EAGER BEAVER 2014	11-	600032-15	14"	32cc
EAGER BEAVER 2014	11-	600032-28	14"	32cc
EAGER BEAVER 2014	11-	600032-34	14"	32cc
EAGER BEAVER 2016	11-	600032-17	16"	32cc
EAGER BEAVER 2016	11-	600032-29	16"	32cc
MAC 3210	11-	600032-03	10"	32cc
MAC 3212	11-/21-	600032-73	12"	32cc
MAC 3214	11-/21-/22-	600032-07	14"	32cc
MAC 3214	11-	600032-25	14"	32cc
MAC 3214	11-	600032-32	14"	32cc
MAC 3214	11-	600032-36	14"	32cc
MAC 3214	11-	600032-42	14"	32cc
MAC 3214	11-/21-/22-	600032-69	14"	32cc
MAC 3214	11-	600032-76	14"	32cc
MAC 3216	11-/21-/22-	600032-09	16"	32cc
MAC 3216	11-	600032-27	16"	32cc
MAC 3216	11-	600032-30	16"	32cc
MAC 3216	11-	600032-31	16"	32cc
MAC 3216	11-	600032-33	16"	32cc
MAC 3216	11-/21-/22-	600032-43	16"	32cc
MAC 3216	11-/21-/22-	600032-68	16"	32cc
MAC 3216	11-/21-	600032-77	16"	32cc
MAC 3216	11-/21-	600032-78	16"	32cc
MAC 3216	11-/21-	600032-80	16"	32cc
MAC 3216	11-/21-	600032-81	16"	32cc
MAC 3216	11-/21-	600032-82	16"	32cc
MAC 3216	21-/22-	600032-83	16"	32cc
MAC 3516	21-/22-	600035-55	16"	35cc
MAC 3516	21-/22-	600035-56	16"	35cc
MAC 3516	21-/22-	600035-58	16"	35cc
POWERMACH 145-14	22-	600032-54	14"	32cc
POWERMACH 225-16	22-	600035-60	16"	35cc
PROMAC 3205-14	22-	600032-10	14"	32cc
SILVER EAGLE 2012 S	11-	600032-21	12"	32cc
SILVER EAGLE 2012 S	11-	600032-59	12"	32cc
SILVER EAGLE 2012	11-	600032-70	12"	32cc
SILVER EAGLE 2014 S	11-	600032-19	14"	32cc
SILVER EAGLE 2014	11-	600032-71	14"	32cc
SILVER EAGLE 2016 S	11-	600032-23	16"	32cc
SILVER EAGLE 2016	11-	600032-72	16"	32cc

MARCH 2003

McCulloch products are identified by a model number (in this instance 600035) followed by a suffix number (08). Suffix numbers denote variations in parts or assemblies used in the manufacture of this product.

Illustrated Parts Lists (IPLs) contain a PART NUMBER, DESCRIPTION, UNITS per assembly and STOCKING CODE for each part.

Stocking Codes are:

- A - Dealer stocked. Fast to medium moving part.
- B - Distributor stocked. Medium to slow moving part.
- C - Factory stocked. Slow moving part.

NOTE:The following explains symbols and footnotes in this IPL:

- (-) A dash preceding a PART NUMBER indicates that it is a new part number, different from the one listed in the previous IPL for this unit.
- (.) One or more dots (. Spring, Starter) preceding a part DESCRIPTION indicates the part is included in the kit or assembly described directly above the dot(s).
- (-- --) If four dashes appear in place of a PART NUMBER, the part is not available individually but is included in the next higher assembly or subassembly.
- Ⓢ Circled numbers preceding a DESCRIPTION footnote the part or assembly to additional information on the page.
- (*) An asterisk denotes that choices follow or precede.
- (+) Serial Number Prefix 21- or denotes CARB approved unit -- all parts are interchangeable with Serial Number Prefix 11-.

The policy of McCulloch is one of continual improvement in design, manufacturing and engineering advancement wherever possible to assure still finer power tools. Hence, specifications, equipment colors, design and manufacturer's suggested list prices are subject to change without notice. McCulloch reserves the right to make such changes without prior notification or obligation to backfit or supply backfit components for units previously shipped from the factory.

ILLUSTRATED PARTS LIST

P.O. Box 31567
Tucson, Arizona 85751-1567 • U.S.A.

FIGURE 1

GENERAL ASSEMBLY

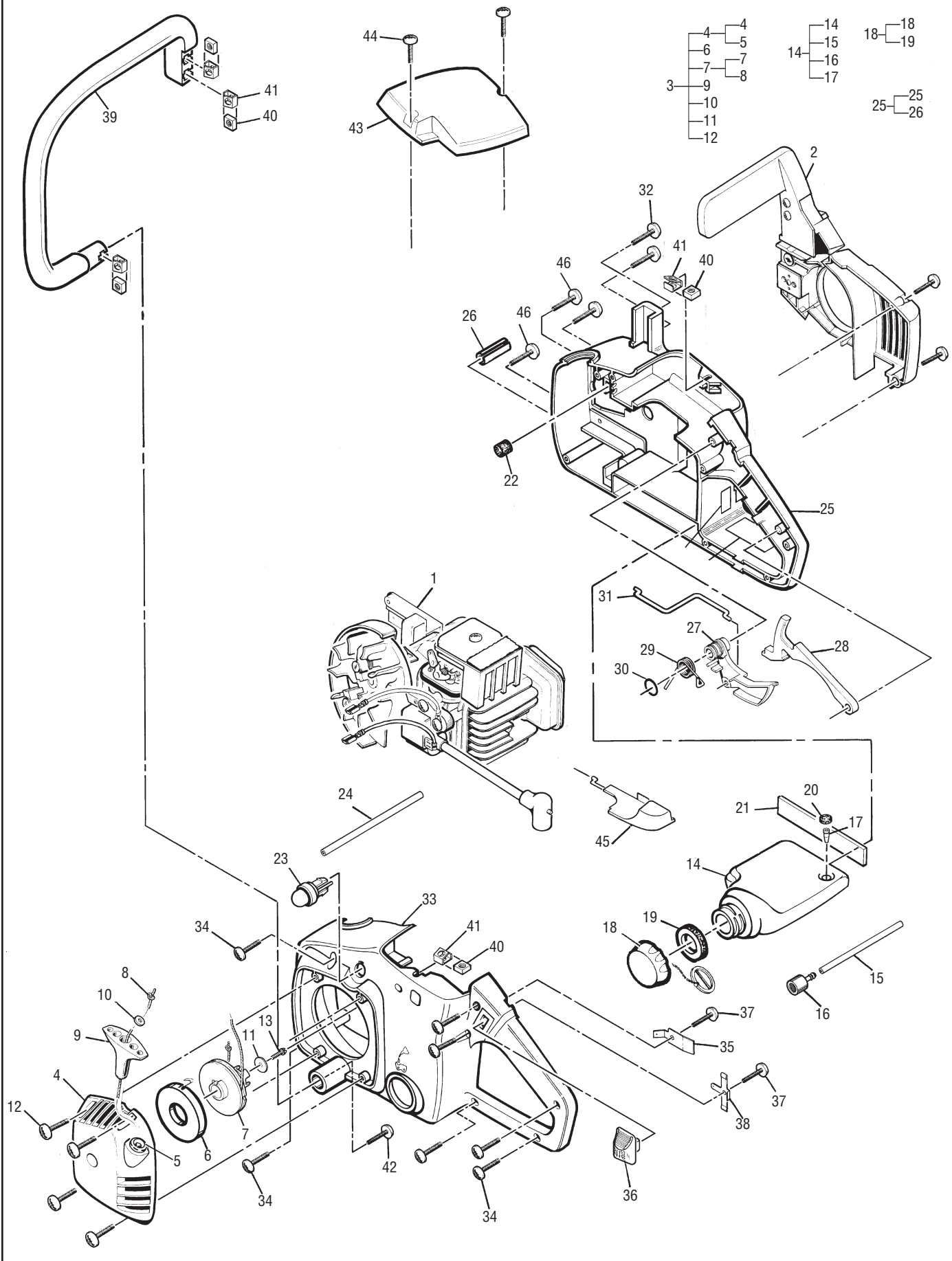

GENERAL ASSEMBLY

FIGURE 1

ITEM NO.	STK CODE	PART NUMBER	DESCRIPTION	UNITS PER ASY
1	-	FIGURE 2	Powerhead Asy	
2	-	FIGURE 3	Chain Brake Asy	
3	A	MC-300264	Starter Housing Asy, Yellow	1
4	B	MC-301044	Housing/Rope Guide Asy, Yellow	1
5	-	---	Rope Guide	1
6	A	MC-30047	Spring, Starter Rewind	1
7	A	MC-301043	Rope/Drum Asy (32cc)	1
8	A	MC-300300	Rope, Starter 50"	1
9	A	MC-87851	Handle, Starter	1
10	A	MC-223944	Bushing, Starter	1
11	A	MC-300297	Washer, .19 ID x .68 OD	1
12	A	MC-300294	Screw, 8-16 x .75 Torx Hd Plast	1
13	A	MC-300294	Screw, 8-16 x .75 Torx Hd Plastite	4
14	B	MC-300260	Oil Tank Asy	1
15	A	MC-300289	Hose, Oil Pick-up	1
16	A	MC-92465	Pickup, Oil	1
17	A	MC-300256	Valve, Duckbill	1
18	A	MC-300565	Oil Cap Asy	1
19	-	---	Gasket	1
20	A	MC-300259	Filter, Foam	1
21	B	MC-322195	Spacer, Oil Tank	1
22	A	MC-300259	Filter, Foam	1
23	A	MC-224242-02	Primer, Remote	1
24	A	MC-300298	Hose	1
25	C	MC-301049	Housing/Pin Asy, Right	1
26	-	---	Pin, Roll 1/4 x 1.0 L	1
27	A	MC-224821	Trigger, Throttle	1
28	B	MC-224822	Latch, Throttle	1

ITEM NO.	STK CODE	PART NUMBER	DESCRIPTION	UNITS PER ASY
29	A	MC-224823	Spring, Torsional	1
30	B	MC-111128	"O" Ring	1
31	B	MC-224827	Rod, Throttle	1
32	A	MC-111226	Screw, 10-24 x .62 Tr Hd Torx	2
33	B	MC-323945-61	Engine Housing, Left, Blk	1
34	A	MC-300294	Screw, 8-16 x .75 Tr Hd, Plastite	7
35	C	MC-224845	Contact, Ground	1
36	A	MC-68846	Button, Stop Switch	1
37	A	MC-223357	Screw, 8-16 Plastite	2
38	B	MC-224844	Contact, Ignition	1
39	B	MC-224836-01	Handle, Front	1
40	A	MC-218005	Nut, Square 10-24	5
41	A	MC-300292	Retainer, Nut	5
42	A	MC-217936	Screw, 10-24 x .75 Tr Torx	1
*43	B	MC-224830	Cover, Air Filter	1
44	A	MC-111099	Screw, 10-24 x .625 Pn Hd Torx	2
45	A	MC-224826-01	Slide, Choke	1
46	A	MC-111226	Screw, 10-24 x .62 Tr Hd Torx	4

ENGINE SPECIFICATIONS

Displacement	.32cc (2.0 ci)
	35cc (2.1 ci)
Spark Plug	RDJ7Y
Spark Plug Gap	.025 in. (0.63mm)
Flywheel to Ignition Gap	0.010-0.015 in. (0.254-0.381mm)
Max Power Speed	8000 RPM
Idle Speed	2800-3300 RPM
Clutch Engagement Speed	3800-4000 RPM
Max No Load Speed	11,000 RPM
Fuel Tank Capacity	10 fl. oz
Oil Tank Capacity	.61 fl. oz
Starter Rope	Nylon, 50 in.

TORQUE SPECIFICATIONS

DESCRIPTION	FASTENER PART NO.	FIG/ ITEM	TORQUE (IN/LBS)	LOCTITE
Right Hsg to C'case	111226	1/32	40-50	262
Oil Pump to C'case	111226	2/9	30-40	262
Carb Insul to Cyl	217937	2/54	30-40	262
Spark Plug	322208	2/19	150	--
Flywheel Nut	110961	2/31	180	--
Clutch Nut	111079	2/69	180	--
Muffler Screws	111093	2/49	50	--
Carburetor Screws	218083	2/56	30-40	262

FIGURE 2

POWERHEAD ASSEMBLY

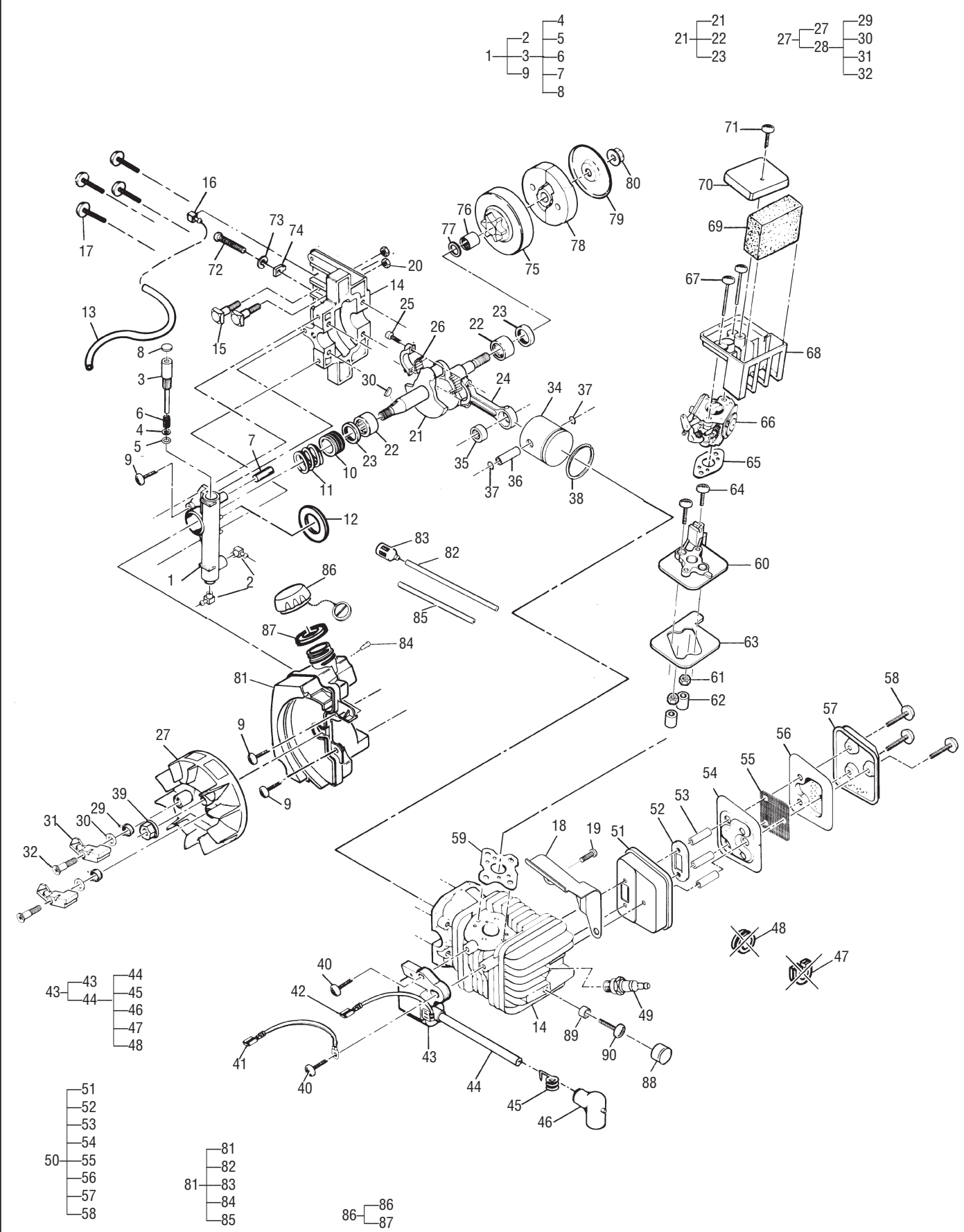

POWERHEAD ASSEMBLY

FIGURE 2

ITEM NO.	STK CODE	PART NUMBER	DESCRIPTION	UNITS PER ASY	ITEM NO.	STK CODE	PART NUMBER	DESCRIPTION	UNITS PER ASY
1	A	MC-301304	Oil Pump Asy	1	50	B	MC-301045	Muffler Asy	1
2	B	MC-322182	Fitting	2	51	-	---	Body	1
3	A	MC-301084	Kit, Gear/Plunger Asy	1	52	-	---	Plate, Reinforcing	1
4	A	MC-110582	Washer	1	53	-	---	Spacer	3
5	-	---	O-Ring	1	54	-	---	Baffle, Inner Muffler	1
6	-	---	Spring	1	55	B	MC-300286	Screen, Spark Arrester	1
7	-	---	Pin, Dowel	1	56	-	---	Baffle, Outer	1
8	B	MC-322187	Plug, Oil Pump	1	57	-	---	Cover, Muffler	1
9	A	MC-111226	Screw, 10-24 x .62 Tr Hd Torx	2	58	B	MC-111093	Screw, 10-24 x 1.75 Tr Hd Torx	3
10	A	MC-224814	Worm Gear	1	59	A	MC-300265 ②	Gasket, Insulator	1
11	A	MC-224840	Spring, Compression	1	60	A	MC-224820	Insulator, Carburetor	1
12	A	MC-300295 ②	Seal, Foam, Oil Pump	1	61	A	MC-218315	Nut, Hx 10-24	2
13	A	MC-300288	Connecting Hose	1	62	A	MC-322188	Spacer, Rubber	2
14	A	MC-301284 ①②	Short Block Asy	1	63	A	MC-224850	Seal, Foam	1
15	A	MC-83856-01②	Bolt, Bar	2	64	B	MC-217937	Screw, Tr 10-24 x 1.00 Torx	2
16	B	MC-300257 ②	Fitting	1	65	A	MC-300293 ②	Gasket, Carburetor	1
17	A	MC-111083 ②	Screw, 12-24 x 1.0 Hx Wshr Hd	4	66	-	FIGURE 4	Carburetor/Choke Asy	1
18	C	MC-323923 ②	Baffle, Air	1	67	A	MC-218083	Screw, Tr 10-24 x 2.0 Torx	2
19	A	MC-111054 ②	Screw, 10-24x.625	1	68	C	MC-224824	Box, Air Filter	1
20	A	MC-110676	Nut, Hx 1/4-28 Flange	2	69	A	MC-224831	Filter, Air	1
21	-	---	Crankshaft/Bearing Asy	1	70	B	MC-224825	Shield, Carburetor	1
22	A	MC-213282	Bearing, C'shaft	2	71	A	MC-111055	Screw, 10-14 x .625 Plastite	1
23	A	MC-83859	Seal, C'shaft Oil	2	72	A	MC-268656-33	Gas Bar Adj Screw Nut & Ring	1
24	-	---	①② Connecting Rod/Bearing	1	73	-	---	Ring, Retaining	1
25	-	---	② Screw, Conn Rod	2	74	-	---	Nut, Bar Adjusting	1
26	-	---	② Set, Roller Pins	1	75	A	MC-302768	Drum/Sprocket/Bearing Asy	1
27	B	MC-302220	Flywheel/Pawl Asy	1	76	A	MC-91117	Bearing	1
28	A	MC-300763-01	Kit, Flywheel Pawls	2	77	B	MC-215259	Washer, Sprocket	1
29	A	MC-216982	Spring, Starter Pawl	2	78	A	MC-301463	Kit, Clutch Asy	1
30	C	MC-111131	Washer, Sp .469 OD x .222 ID	2	79	B	MC-300276	Plate, Dust	1
31	-	---	Pawls	2	80	A	MC-111079	Nut, Clutch, 5/16-24 LH	1
32	A	MC-322721	Pin, Starter Pawl	2	81	A	MC-301834	Fuel Tank Asy	1
33	A	MC-102164	Key, Flywheel	1	82	A	MC-300289	Hose, Fuel Pickup	1
34	-	---	①② Piston	1	83	A	MC-216985	Filter, Fuel	1
35	-	---	② Bearing, Needle-Drawn Cup	1	84	A	MC-322199	Valve, Duckbill	1
36	-	---	② Pin, Piston	1	85	A	MC-300290	Hose, Primer Retain	1
37	-	---	② Ring, Snap	2	86	A	MC-300564	Cap, Fuel Asy	1
38	-	---	② Piston, Ring	1	87	-	---	Gasket, Fuel Cap	1
39	A	MC-110961	Nut, Hx 5/16-24	1	88	C	MC-322200	Cover Cylinder	1
40	A	MC-217936	Screw, Tr 10-24 x .75 Torx	2	89	C	MC-322201	Cover, Spacer	1
41	B	MC-300555	Wire Asy, Ground	1	90	A	MC-217936	Screw, 10-24x.75 Tr Torx	1
42	B	MC-300556	Wire Asy, Stop Switch	1					
43	A	MC-302138	Ignition Asy	1					
44	A	MC-223884	Kit, Plug Wire	1					
45	A	MC-102556	Connector	1					
46	A	MC-95266	Boot	1					
47	B	MC-110995 ③	Grommet	1					
48	B	MC-215533-0①	Grommet	1					
49	A	MC-322208 ②	Spark Plug RDJ7Y	1					

① 32cc piston and cylinder are no longer available; for replacement parts the 38cc Shortblock Asy, PN 301284, must be used

② Contents of 38cc Shortblock Asy, PN 301284

③ Not used on these models

FIGURE 3

CHAIN BRAKE ASSEMBLY

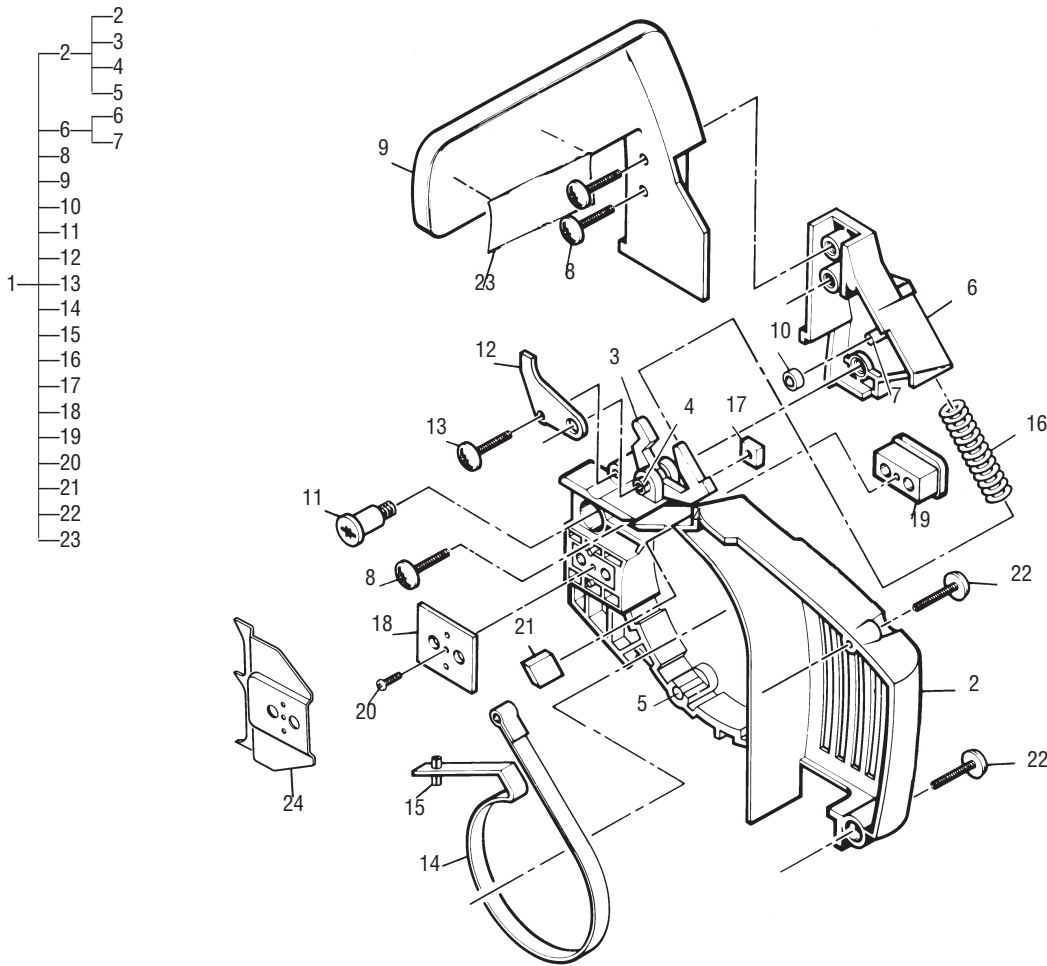

ITEM NO.	STK CODE	PART NUMBER	DESCRIPTION	UNITS PER ASY
1	C	MC-301558	Brake Kit Asy, Yellow	1
2	C	MC-301559	Housing Kit Asy, Yellow	1
3	C	MC-216755	Latch, Chain Brake	1
4	-	---	Dowel, Spring	2
5	-	---	Pin, Dowel	2
6	B	MC-301038	Lever, Brake Asy	1
7	-	---	Pin, Dowel	1
8	A	MC-111226	Screw, 10-24 x .62 Tr Hd Torx	3
9	A	MC-323082	Guard, Hand	1
10	B	MC-224849	Roller	1
11	B	MC-224847	Screw, Shoulder	1
12	B	MC-224848	Stop, Brake	1
13	A	MC-300294	Screw, 8-16 x .75 Tr Hd Plastite	1
14	A	MC-301037	Band, Brake	1
15	-	---	Pin, Spring (.125 x .50)	1
16	A	MC-322204	Spring, Compression	1
17	A	MC-218005	Nut, Square 10-24	1

ITEM NO.	STK CODE	PART NUMBER	DESCRIPTION	UNITS PER ASY
18	B	MC-300275	Shield	1
19	B	MC-300271	Spacer, Bar Pad	1
20	C	MC-111101	Screw, 4-40 x 5/16 Taptite	1
21	A	MC-322194	Seal, Foam	1
22	A	MC-300299	Screw, 8-16 x 1.0 Tr Hd Plastite	2
23	B	MC-46703-41	Label, Safety	1
24	B	MC-322181	Spike, Bucking	1

* Choose appropriate color
 ① Optional accessory

BAR AND CHAIN INFORMATION

BAR AND CHAIN SIZE	BAR PART NUMBER	CHAIN PART NUMBER	CHAIN SPECIFICATIONS	SERVICE TOOLS	
				FILE AND GUIDE PN	FILE PN (Description)
10"	MC-214233-33	MC-214923-33	MPG370GLX38cl	301992-33 (5/32)	214217-33 (5/32)
12"	MC-214234-33	MC-214921-33	MPG370GLX44cl		
14"	MC-214235-33	MC-214919-33	MPG370GLX49cl		
16"	MC-214236-33	MC-214925-33	MPG370GLX54cl		

FIGURE 4

CARBURETOR ASSEMBLY

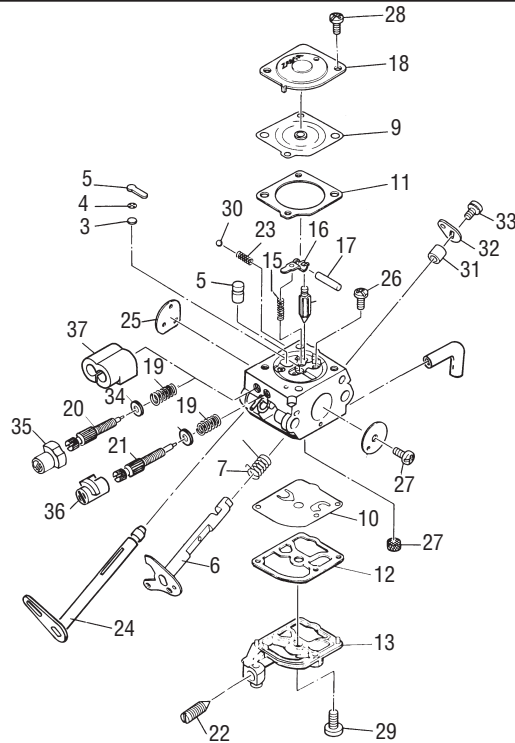

ITEM NO.	STK CODE	PART NUMBER	DESCRIPTION	UNITS PER ASY
	B	MC-323653-03	③ Carburetor, Zama CU1M28C	
	B	MC-324947-01	④ Carburetor, Zama C1QM36	
1	---	---	① Strainer	1
2	---	---	① Plug, Welch	1
3	---	---	Valve, Check	1
4	---	---	Retainer, Check Valve	1
5	---	---	Nozzle Asy, Check Valve	1
6	---	---	Shaft Asy, Throttle	1
7	---	---	Spring, Throttle Return	1
8	---	---	Valve, Throttle	1
9	---	---	①② Diaphragm Asy, Metering	1
10	---	---	①② Diaphragm, Pump	1
11	---	---	①② Gasket, Metering Chamber	1
12	---	---	①② Gasket, Pump	1
13	---	---	Cover, Pump	1
14	---	---	① Valve, Inlet Needle	1
15	---	---	① Spring, Metering Lever	1
16	---	---	① Lever, Metering	1
17	---	---	① Pin	1
18	---	---	Cover, Metering Chamber	1
19	---	---	Spring, Adjust Screw	2
20	---	---	Screw, Main Mixture	1
21	---	---	Screw, Idle Mixture	1
22	---	---	Screw, Throttle Adjust	1
23	---	---	Spring, Friction	4
24	---	---	Shaft Asy, Choke	1
25	---	---	Valve, Choke	1
26	---	---	Screw, Pin	1
27	---	---	Screw, Throttle/Choke Valve	1
28	---	---	Screw, Metering Chamber	2
29	---	---	Screw, Pump Cover	1
30	---	---	Ball, Steel	1
31	---	---	Collar	1
32	---	---	Lever, Throttle	1
33	---	---	Screw, Throttle Lever	1
34	---	---	Washer, Limiter	2
35	B	MC-111216	Cap, Limiter, Hi	1
36	B	MC-111217	Cap, Limiter, Lo	1
37	---	---	Retainer, Limiter	1
①	301041	Kit, Carburetor Repair RB-39 (Stk Code A)		
②	301042	Kit, Gasket/Diaphragm GND-35 (Stk Code A)		
③	Can be used on 32/35cc models with serial number prefixes 11-, 21-			
④	Can be used on 32/35cc models with serial number prefixes 11-, 21-, 22-			

ITEM NO.	STK CODE	PART NUMBER	DESCRIPTION	UNITS PER ASY
-	B	MC-323653-04	③ Carburetor, Walbro WT 438	
1	---	---	① Strainer	1
2	---	---	① Plug, Welch	1
3	---	---	Valve, Check	1
4	---	---	Retainer, Check Valve	1
5	---	---	Nozzle Asy, Check Valve	1
6	---	---	Shaft Asy, Throttle	1
7	---	---	Spring, Throttle Return	1
8	---	---	Valve, Throttle	1
9	---	---	①② Diaphragm Asy, Metering	1
10	---	---	①② Diaphragm, Pump	1
11	---	---	①② Gasket, Metering Chamber	1
12	---	---	①② Gasket, Pump	1
13	---	---	Cover, Pump	1
14	---	---	① Valve, Inlet Needle	1
15	---	---	① Spring, Metering Lever	1
16	---	---	① Lever, Metering	1
17	---	---	① Pin	1
18	---	---	Cover, Metering Chamber	1
19	---	---	Spring, Adjust Screw	2
20	---	---	Screw, Main Mixture	1
21	---	---	Screw, Idle Mixture	1
22	---	---	Screw, Throttle Adjust	1
23	---	---	Spring, Friction	4
24	---	---	Shaft Asy, Choke	1
25	---	---	Valve, Choke	1
26	---	---	Screw, Pin	1
27	---	---	Screw, Throttle/Choke Valve	1
28	---	---	Screw, Metering Chamber	2
29	---	---	Screw, Pump Cover	1
30	---	---	Ball, Steel	1
31	---	---	Collar	1
32	---	---	Lever, Throttle	1
33	---	---	Screw, Throttle Lever	1
34	---	---	Washer, Limiter	2
35	B	MC-325465	Cap, Limiter, Hi	1
36	B	MC-325466	Cap, Limiter, Lo	1
37	---	---	Retainer, Limiter	1
①	324013	Kit, Carburetor Repair A1128WT (Stk Code A)		
②	324009	Kit, Gasket/Diaphragm B1110WT (Stk Code A)		
③	Can be used on 32/35cc models with serial number prefixes 11-, 21-			



P.O. Box 31567 • Tucson, Arizona 85751-1567 • U.S.A.

• MANUFACTURING • SALES • SERVICE •

FOR WARRANTY OR SERVICE,
CONTACT THE NEAREST McCULLOCH AUTHORIZED SERVICE CENTER
LISTED UNDER 'SAWS' IN YOUR TELEPHONE DIRECTORY YELLOW PAGES.

IF FURTHER ASSISTANCE IS REQUIRED CALL THIS TOLL-FREE HOT LINE.
PLEASE REFERENCE YOUR MODEL AND SERIAL NUMBER.

1-800-521-8559

MONDAY - FRIDAY - 6:00 AM - 4:30 PM (MST)

www.mccullochpower.com

